

Nantong Ningyuan Automation Technology CO.,Ltd	文件编号	SPC-TC-001
Product specification	版本	A0
	日期	



磷酸铁锂电池 产品规格书

Lithium iron phosphate battery specification

客户名称:

产品规格: 12V240Ah

发行日期: _____

Prepared 制定	Checked 审核	Approved 批准

1. 适用范围(Product Scope)

本规格书描述了锂离子二次电池的技术要求、测量方法、运输、储存及注意事项。

This Specification describes the requirements of the lithium ion rechargeable battery supplied by

2. 电池特性 (Battery Group Specifications)

Pile Index 参数	Rated Capacity 标称容量	240Ah
	Minimal Capacity最小容量 (0.2C ₅ A)	240Ah
	Nominal Voltage 额定电压	12V
	Nominal Resistance内阻	≤50.0mΩ
	Max. Charge Voltage 最大充电电压	14.6V
	Discharge cut-off voltage放电截止电压	10V
	Charge Current 充电电流	≤100A
	Max Charge Current最大充电电流	100A
	Charge method 充电方法	CC/CV (恒流恒压)
	Continuous Working Current持续工作电流	200A
	Maximum Surge Current 最大脉冲电流	500A
	Dimension外形尺寸 (T×W×L)	(481±1) x (260±1) x (175±1) mm
	Operating Temperature适用温度	Charge 充电
Discharge 放电		-20°C~60°C; -4°F~149°F
Storage 储存		-10°C~35°C; 14°F~95°F

2.1 Box image :

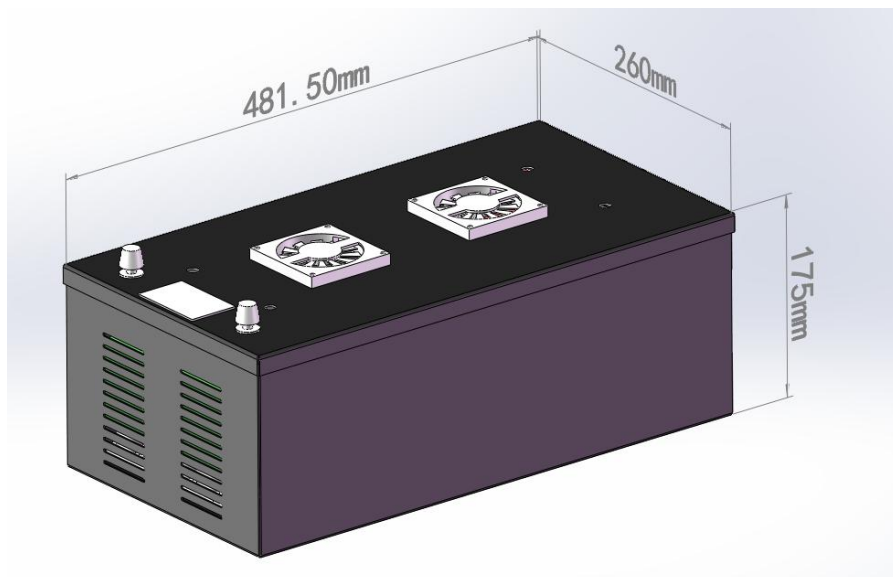

2.2 保护板外形 Configuration of Protective Plate:



2.3 保护板参数 Protective Plate Parameters:

	Description	Specification	Unite	Remarks
Discharge	Continue discharge current	200	A	
	Peak current	500	A	
Charge	Charge voltage	14.6	V	
	Charge current	100 (MAX)	A	
Over charge protection	Over charge detect voltage	3.65±0.05	V	
	over charge protection delay	1	S	
	over charge release voltage	3.6±0.05	V	
Balance	Balance detect Voltage	3.6	V	
	Balance release voltage	3.6	V	
	Balance current	35±5	mA	
Over discharge protection	Over discharge detect voltage	2.5±0.1	V	
	Over discharge detect delay	20	mS	
	Over discharge release voltage	2.5±0.1	V	
Over current protection	Over current detect voltage	/		
	Over current detect delay	100	MS	
	Over current protection current	500	A	as required
	Over current protection release condition	Off load		

Short Circuit protection	Short Circuit protection condition	Short circuit of external load of ext load short con		
	Short circuit detect delay	250	uS	
	Short circuit protection release condition	Off load		
Temp Protect				No
Inner Resistance	Main Circuit Conduct Inner resistance	≤ 20	m Ω	
Self Consumption	Working current	≤ 100	uA	
	Sleeping current (when in discharge)	≤ 20	uA	
Working Temp	Temp range	-20/+70	°C	

2.4 接线图 Wiring diagram:

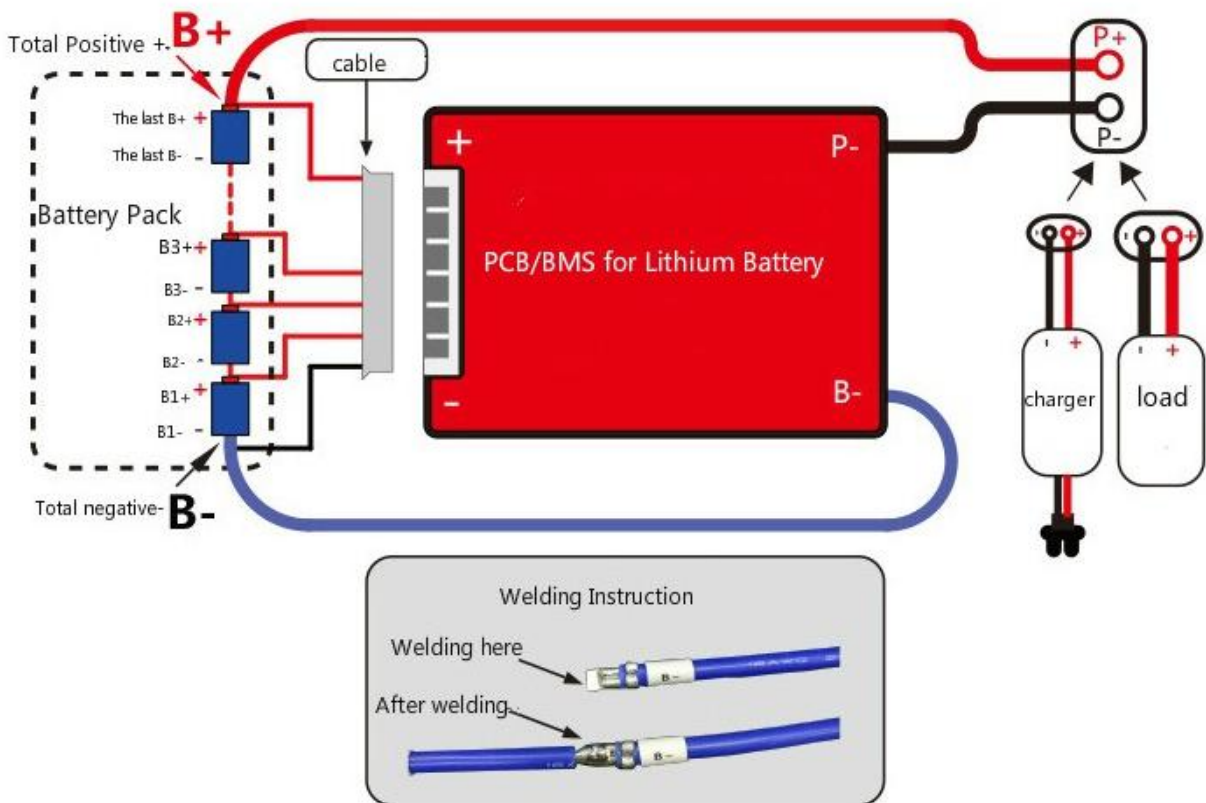

3. 技术要求 (Technical Requirements)

3.1 测试条件 (除特别规定) Testing Conditions (unless otherwise specified)

温度 Temperature: 15~35°C
 相对湿度 Relative Humidity: 45%~75%
 大气压 Atmospheric pressure: 86~106Kpa

3.2 充放电性能 (Electrical Characteristics)

NO	项目(ITEM)	测试方法(Testing Instruction)	要求(Requirements)
1	Standard Charge 标准充电	Charging the cell initially with constant current at 0.2C and then with constant voltage at 14.6V till charge current declines to 0.05C 先用0.2C恒流充电至14.6V，再恒压14.6V充电直至充电电流	
		≤0.05C	
2	Rated Capacity 初始容量	Measure discharge capacity with discharge current 0.2C to 10V cut-off within 1 hour after standard charge. 标准充电方式充电后，以0.2C电流放电至10V的容量	≥240Ah
3	Cycle Life 循环寿命	Measure the capacity after 2000 cycles of standard charge and discharge at 0.2C current to 10V cut-off 标准充电方式充电后，0.2C放电至10V，如此循环2000次后电池的剩余容量	≥80% of Rated Capacity 初始容量的80%
4	Storage Characteristics 储存性能	Capacity after 30days storage at 25°C from standard charge 标准充电方式充电后，25°C下储存30天后的容量	Retention capacity ≥96% 剩余容量≥96%
		Capacity after 7days storage at 40°C from standard charge 标准充电方式充电后，40°C下储存7天后的容量	Recovery capacity ≥96% 剩余容量≥96%

3.3 环境性能 (Environmental Characteristic)

NO	项目(ITEM)	测试方法(Testing Instruction)	要求(Requirements)
1	Temperature testing 高低温测试	Measure capacity with constant discharge current 0.5C to 10V cut-off at each temperature after standard charge at 25°C, Percentage as an index of the capacity compared with 100% at 25°C 25°C下标准充电方式充电后，在指定温度下0.5C放电至10V的容量，并以25°C时放电容量为基准计算百分率	80% at 0°C 100% at 25°C 99% at 60°C
2	Constant temperature /humidity 恒定湿热性能	Keep the battery at 60°C and 90%RH for 12hrs 将电池放入温度为60°C，相对湿度为90%的条件下搁置12小时	Recovery capacity ≥90% 恢复容量≥90%

3.4 安全性能(Safe Characteristic)

NO	项目(ITEM)	测试方法(Testing Instruction)	要求 (Requirements)
1	Short Circuit 短路	<p>After standard charge, the battery located in a fume hood is to be short-circuited by connecting the positive and negative terminals with an external load of less than 50 mΩ till the battery case temperature has returned to near ambient temperature.</p> <p>将标准充电后的电池置于通风橱中，短路其正负极（线路总电阻不大于50mV），实验过程中监视电池温度变化，当电池温度下降到接近初始室温时，结束实验</p>	<p>The battery shall not rupture, smoke, catch fire, vent or leak.</p> <p>电池应无破裂、冒烟、着火、泄漏或漏液</p>
2	Abnormal Charging Test 过充	<p>After discharge to 40V cut-off with discharge current 1C, the battery is to be subjected to a charging current 3C. The specified charging current is to be obtained by connecting a resistor of the specified size and rating in series with the battery. The test time is to be calculated using the formula: $t_c = 40c/3(I_c)$</p> <p>将电池1C放电至2.5V后，调节电流3C充电，充电时间按以下公式计算：$t_c = 2.5 * \text{电池额定容量} / (3 * \text{制造商给定1C电流})$</p>	
3	Over discharge testing 过放	<p>After standard charge, the battery will be connected with external with a maximum resistance load of 0.1Ω for 24hrs until it is completely discharged and the battery case temperature has returned to near ambient temperature.</p> <p>以标准方式充电后，将电池正负端以内阻小于0.1欧姆的铜导线连接24小时，直至电池完全放电，温度下降到环境温度</p>	
4	Puncture 穿刺	<p>After standard charge, the battery located in a fume hood is to be punctured with a nail (diameter \geq 1mm) until it is</p>	
		<p>completely discharged and the battery case temperature has returned to near ambient temperature</p> <p>将标准充电后的电池置于通风橱中，用直径不小于1mm的针将电池从正面刺穿，直至电池完全放电，温度下降到环境温度</p>	

• 保质期限及产品责任 WARRANTY PERIOD & PRODUCT LIABILITY

Warranty period of this product is 18 months from manufacturing code.

保质期是从出厂日期开始起18个月

.Our company is not responsible for the troubles caused by mishandling of the battery which is clearly against the instructions in this specification.

我对因没有按本规格书规定操作而导致的意外不负责任

When Our company finds any new facts which require modification of this document, we will inform you again.

一旦我司发现本规格书有新的修改细节，我们将再告知。

5. 电池使用时警告事项及注意事项

WARNINGS AND CAUTIONS IN HANDLING THE Lithium-ion BATTERY

To prevent a possibility of the battery from leaking, heating or explosion please observe the following precautions:

为防止电池可能发生泄漏,发热、爆炸,请注意以下预防措施:

WARNINGS!

- Do not immerse the battery in water or seawater, and keep the battery in a cool dry surrounding if it stands by.

禁将电池浸入海水或水中,保存不用时,应放置于阴凉干燥的环境中

Do not use or leave the battery near a heat source as fire or heater

禁止将电池在热高温源旁,如火、加热器等使用和留置

- When recharging, use the battery charger specifically for that purpose

充电时请选用锂离子电池专用充电器

- Do not reverse the positive (+) and negative (-) terminals

严禁颠倒正负极使用电池

- Do not connect the battery to an electrical outlet

严禁将电池直接接入电源插座

- Do not discard the battery in fire or heat it

禁止将电池丢于火或加热器中

- Do not short-circuit the battery by directly connecting the positive (+) and negative (-) terminal with metal objects such as wire.

禁止用金属直接连接电池正负极短路

- Do not transport or store the battery together with metal objects such as necklaces, hairpins etc.

禁止将电池与金属,如发夹、项链等一起运输或贮存

- Do not strike or throw the battery

禁止敲击或抛掷、踩踏电池等

- Do not directly solder the battery and pierce the battery with a nail or other sharp object.

禁止直接焊接电池和用钉子或其它利器刺穿电池

CAUTIONS!

- Do not use or leave the battery at very high temperature (for example, at strong direct sunlight or in a vehicle in extremely hot weather). Otherwise, it can overheat or fire or its performance will be degenerated and its service life will be decreased.

禁止在高温下(炙热的阳光下或很热的汽车中)使用或放置电池,否则可能会引起电池过热、起火或功能失效、寿命减短。

- If the battery leaks, and the electrolyte get into the eyes. Do not rub eyes, instead, rinse the eyes with clean running water, and immediately seek medical attention. Otherwise, it may injure eyes or cause a loss of sight.

如果电池发生泄露,电解液进入眼睛,请不要揉擦,应用清水冲洗眼睛,并立即送医院治疗,否则会伤害眼睛。

- If the battery gives off an odor, generates heat, becomes discolored or deformed, or in any way appear abnormal during use, recharging or storage, immediately remove it from the device or battery charger and stop using it.

如果电池发出异味,发热、变色、变形或使用、贮存,充电过程中出现任何异常,立即将电池从装置或充电器中移离并停用。

- In case the battery terminals are dirty, clean the terminals with a dry cloth before use. Otherwise power failure or charge failure may occur due to the poor connection with the instrument.

如果电极弄脏,使用前应用干布抹净,否则可能会导致接触不良功能失效。

- Be aware discarded batteries may cause fire, tape the battery terminals to insulate them

废弃之电池应用绝缘纸包住电极,以防起火、爆炸。